

PRODUCT SPECIFICATION

产品规格书

Customer 客户名称: _____

Product Name 品名: 片式NTC热敏电阻 Chip NTC thermistor

PART NO. 型号规格: NTC0201

Issue Date 发布日期: _____

Prepared 制作	Checked 审核	Customer Check 客户核准
ChenTT	Zelig	

1 外形尺寸 Shape and Dimensions

尺寸: 见图 1 和表 1

Dimensions: See Fig.1 and Table 1.

PCB 焊盘: 见图 2 和表 1

Recommended PCB pattern for reflow soldering: See Fig.2 and Table 1



图 1 Fig.1



图 2 Fig.2

表 1 (Table 1)

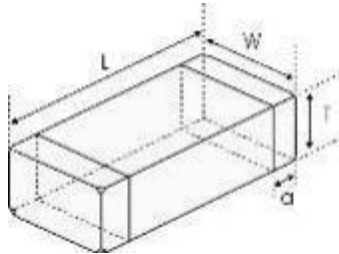
单位 unit: inch[mm]

类别 Type	L	W	T	a	A	B	C
0201 [0603]	0.024±0.002 [0.6±0.05]	0.012±0.002 [0.3±0.05]	0.012±0.002 [0.3±0.05]	0.006±0.002 [0.15±0.05]	[0.2-0.3]	[0.25-0.35]	[0.25-0.35]

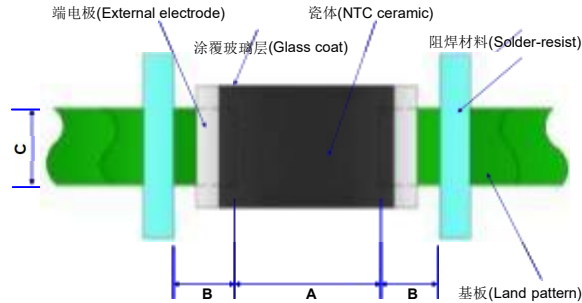
2 产品标识 (料号) Product Identification(Part Number)

NTC 0201 X 103 F 3435 F A
 ① ② ③ ④ ⑤ ⑥ ⑦ ⑧

① 类别 Type	
NTC	片式 NTC 热敏电阻器 Chip NTC Thermistor

② 外形尺寸(mm) External Dimensions (L×W×T)	
0201[0603]	0.60×0.30×0.30
0402[1005]	1.00×0.50×0.50
0603[1608]	1.60×0.80×0.80
0805[2012]	2.00×1.25×0.85

③ 分隔符 Delimiter	
X	

④ 25℃的零功率电阻 Nominal Zero-Power Resistance at 25℃	
222	2.2kΩ
103	10kΩ
474	470kΩ

⑤ 电阻值公差 Tolerance of Resistance	
F	±1%
G	±2%
H	±3%
J	±5%

⑥ B 值常数 B Constant	
3435	3435K
3950	3950K
4250	4250K

⑦ B 值公差 Tolerance of B Constant	
F	±1%
H	±3%

⑧ B 值计算方式 B constant calculation method	
A	25℃ & 85℃
B	25℃ & 50℃

3 电气特性 Electrical Characteristics

1) F 档 F Series

型号 Part No	电阻值 Resistance (25°C) (kΩ)	B 常数 B Constant (25/50°C) (K)	B 常数 B Constant (25/85°C) (K)	允许工作电流 Permissible Operating Current (25°C) (mA)	耗散系数 Dissipation Factor (mW/°C)	热时间常数 Thermal Time Constant (s)	额定功率 Rated Electric Power(25°C) (mW)	工作温度 Operating ambient temperature (°C)
NTC0201X103F3435FA	10±1%	3380	3435±1%	0.31	1.0	<3	100	-40~+125
NTC0201X473F4050FB	47±1%	4050±1%	4100	0.14				
NTC0201X683F4150FB	68±1%	4150±1%	4210	0.12				
NTC0201X104F4250FB	100±1%	4250±1%	4310	0.10				

2) H 档 H Series

型号 Part No	电阻值 Resistance (25°C) (kΩ)	B 常数 B Constant (25/50°C) (K)	B 常数 B Constant (25/85°C) (K)	允许工作电流 Permissible Operating Current (25°C) (mA)	耗散系数 Dissipation Factor (mW/°C)	热时间常数 Thermal Time Constant (s)	额定功率 Rated Electric Power(25°C) (mW)	工作温度 Operating ambient temperature (°C)
NTC0201X103H3435FA	10±3%	3380	3435±1%	0.31	1.0	<3	100	-40~+125
NTC0201X473H4050FB	47±3%	4050±1%	4100	0.14				
NTC0201X683H4150FB	68±3%	4150±1%	4210	0.12				
NTC0201X104H4250FB	100±3%	4250±1%	4310	0.10				

3) J 档 J Series

型号 Part No	电阻值 Resistance (25°C) (kΩ)	B 常数 B Constant (25/50°C) (K)	B 常数 B Constant (25/85°C) (K)	允许工作电流 Permissible Operating Current (25°C) (mA)	耗散系数 Dissipation Factor (mW/°C)	热时间常数 Thermal Time Constant (s)	额定功率 Rated Electric Power(25°C) (mW)	工作温度 Operating ambient temperature (°C)
NTC0201X103J3435FA	10±5%	3380	3435±1%	0.31	1.0	<3	100	-40~+125
NTC0201X473J4050FB	47±5%	4050±1%	4100	0.14				
NTC0201X683J4150FB	68±5%	4150±1%	4210	0.12				
NTC0201X104J4250FB	100±5%	4250±1%	4310	0.10				

· 我司可根据客户需求定制特殊规格产品。 Special products can be customized.

4 检验和测试程序

测试条件

如无特别规定，检验和测试的标准大气环境条件如下：

- a. 环境温度：20±15℃；
- b. 相对湿度：65±20%；
- c. 气压：86 kPa~106 kPa

如果对测试结果有异议，则在下述条件下测试：

- a. 环境温度：25±2℃；
- b. 相对湿度：65±5%
- c. 气压：86kPa~106kPa

检查设备

外观检查：20 倍放大镜；
阻值检查：热敏电阻测试仪

4 Test and Measurement Procedures

Test Conditions

Unless otherwise specified, the standard atmospheric conditions for measurement/test as:

- a. Ambient Temperature: 20±15 °C
- b. Relative Humidity: 65±20%
- c. Air Pressure: 86kPa to 106kPa

If any doubt on the results, measurements/tests should be made within the following limits:

- a. Ambient Temperature: 25±2 °C
- b. Relative Humidity: 65±5%
- c. Air Pressure: 86kPa to 106kPa

Inspection Equipment

Visual Examination: 20 × magnifier
Resistance value test: Thermistor resistance tester

5 电性测试 Electrical Test

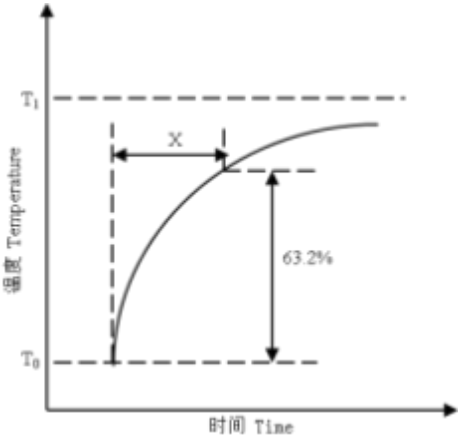
序号 No.	项目 Items	测试方法及备注 Test Methods and Remarks
1	25℃零功率电阻值 Nominal Zero-Power Resistance at 25℃(R25)	环境温度 Ambient temperature: 25±0.05℃ 测试功率 Measuring electric power: ≤0.1mW
2	B 值常数 Nominal B Constant	分别在环境温度 25±0.05℃, 50±0.05℃或 85±0.05℃下测量电阻值。 Measure the resistance at the ambient temperature of 25±0.05℃, 50±0.05℃ or 85±0.05℃. $B(25-50^{\circ}\text{C}) = \frac{1^{\text{st}}R_{25} - \ln R_{50}}{1/T_{25} - 1/T_{50}}$ $B(25-85^{\circ}\text{C}) = \frac{1^{\text{st}}R_{25} - \ln R_{85}}{1/T_{25} - 1/T_{85}}$ T: 绝对温度 (K) Absolute temperature (K)
3	热时间常数 Thermal Time Constant	在零功率条件下，当热敏电阻的环境温度发生急剧变化时，热敏电阻元件产生最初温度 T0 与最终温度 T1 两者温度差的 63.2% 的温度变化所需要的时间，通常以秒(S)表示。 The total time for the temperature of the thermistor to change by 63.2% of the difference from ambient temperature T ₀ (°C) to T ₁ (°C) by the drastic change of the power applied to thermistor from Non-zero Power to Zero-Power state, normally expressed in second(S). 

片式 NTC 热敏电阻规格书 Specifications for Chip NTC thermistor

4	耗散系数 Dissipation Factor	<p>在一定环境温度下，NTC 热敏电阻通过自身发热使其温度升高 1℃ 时所需要的功率，通常以 mW/℃ 表示。可由下面公式计算：</p> <p>The required power which makes the NTC thermistor body temperature raise 1℃ through self-heated, normally expressed in milliwatts per degree Celsius (mW/℃). It can be calculated by the following formula:</p> $\delta = \frac{W}{T - T_0}$
5	额定功率 Rated Power	<p>在环境温度 25℃ 下因自身发热使表面温度升高 100℃ 所需要的功率。</p> <p>The necessary electric power makes thermistor's temperature rise 100℃ by self-heating at ambient temperature 25℃.</p>
6	允许工作电流 Permissible operating current	<p>在静止空气中通过自身发热使其升温为 1℃ 的电流。</p> <p>The current that keep body temperature of chip NTC on the PC board in still air rising 1℃ by self-heating.</p>

6 信赖性试验 Reliability Test

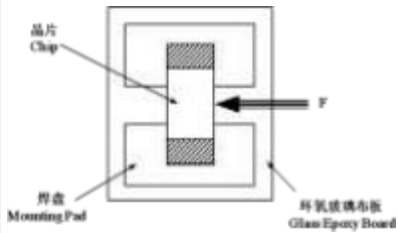
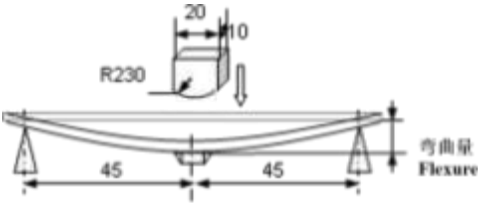
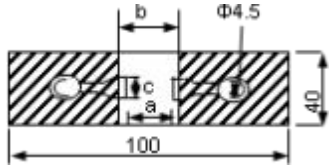
项目 Items	测试标准 Standard	测试方法及备注 Test Methods and Remarks	要求 Requirements																														
端头附着力 Terminal Strength	IEC 60068-2-21	<p>将晶片焊接在测试基板上（如右图所示的环氧玻璃布板），按箭头所示方向施加作用力；</p> <p>Solder the chip to the testing jig (glass epoxy board shown in the right) using eutectic solder. Then apply a force in the direction of the arrow.</p> <table border="1"> <thead> <tr> <th>尺寸 Size</th> <th>F</th> <th>保持时间 Duration</th> </tr> </thead> <tbody> <tr> <td>0201</td> <td>2N</td> <td rowspan="3">10±1s</td> </tr> <tr> <td>0402, 0603</td> <td>5N</td> </tr> <tr> <td>0805</td> <td>10N</td> </tr> </tbody> </table>	尺寸 Size	F	保持时间 Duration	0201	2N	10±1s	0402, 0603	5N	0805	10N	<p>端电极无脱落且瓷体无损伤。</p> <p>No removal or split of the termination or other defects shall occur.</p> 																				
尺寸 Size	F	保持时间 Duration																															
0201	2N	10±1s																															
0402, 0603	5N																																
0805	10N																																
抗弯强度 Resistance to Flexure	IEC 60068-2-21	<p>将晶片焊接在测试基板上（如右图所示的环氧玻璃布板），按下图箭头所示方向施加作用力；</p> <p>Solder the chip to the test jig (glass epoxy board shown in the right) using a eutectic solder. Then apply a force in the direction shown as follow;</p>  <table border="1"> <thead> <tr> <th>尺寸 Size</th> <th>弯曲变形量 Flexure</th> <th>施压速度 Pressurizing Speed</th> <th>保持时间 Duration</th> </tr> </thead> <tbody> <tr> <td>0201,</td> <td>1mm</td> <td rowspan="2"><0.5mm/s</td> <td rowspan="2">10±1s</td> </tr> <tr> <td>0402, 0603, 0805</td> <td>2mm</td> </tr> </tbody> </table>	尺寸 Size	弯曲变形量 Flexure	施压速度 Pressurizing Speed	保持时间 Duration	0201,	1mm	<0.5mm/s	10±1s	0402, 0603, 0805	2mm	<p>① 无外观损伤。 No visible damage.</p> <p>② $\Delta R_{25}/R_{25} \leq 2\%$</p> <p>单位 unit: mm</p> <table border="1"> <thead> <tr> <th>类型 Type</th> <th>a</th> <th>b</th> <th>c</th> </tr> </thead> <tbody> <tr> <td>0201</td> <td>0.25</td> <td>0.3</td> <td>0.3</td> </tr> <tr> <td>0402</td> <td>0.4</td> <td>1.5</td> <td>0.5</td> </tr> <tr> <td>0603</td> <td>1.0</td> <td>3.0</td> <td>1.2</td> </tr> <tr> <td>0805</td> <td>1.2</td> <td>4.0</td> <td>1.65</td> </tr> </tbody> </table> 	类型 Type	a	b	c	0201	0.25	0.3	0.3	0402	0.4	1.5	0.5	0603	1.0	3.0	1.2	0805	1.2	4.0	1.65
尺寸 Size	弯曲变形量 Flexure	施压速度 Pressurizing Speed	保持时间 Duration																														
0201,	1mm	<0.5mm/s	10±1s																														
0402, 0603, 0805	2mm																																
类型 Type	a	b	c																														
0201	0.25	0.3	0.3																														
0402	0.4	1.5	0.5																														
0603	1.0	3.0	1.2																														
0805	1.2	4.0	1.65																														

片式 NTC 热敏电阻规格书 Specifications for Chip NTC thermistor

<p>振动 Vibration</p>	<p>IEC 60068-2-80</p>	<p>① 将晶片焊接在测试基板上（如右图所示的环氧玻璃布板）； Solder the chip to the testing jig (glass epoxy board shown in the left) using eutectic solder.</p> <p>② 晶片以全振幅为 1.5mm 进行振动，频率范围为 10Hz ~55 Hz； The chip shall be subjected to a simple harmonic motion having total amplitude of 1.5mm, the frequency being varied uniformly between the approximate limits of 10 and 55 Hz.</p> <p>③ 振动频率按 10Hz→55Hz→10Hz 循环，周期为 1 分钟，在空间三个互相垂直的方向上各振动 2 小时（共 6 小时）。 The frequency ranges from 10 to 55 Hz and return to 10 Hz shall be traversed in approximately 1 minute. This motion shall be applied for a period of 2 hours in each 3 mutually perpendicular directions (total of 6 hours).</p>	<p>无外观损伤。 No visible damage.</p>  <p>铜箔 Chip pad 阻焊膜 Solder mask 环氧玻璃布板 Glass Epoxy Board</p>															
<p>坠落 Dropping</p>	<p>IEC 60068-2-32</p>	<p>从 1m 的高度让晶片自由坠落至水泥地面 10 次。 Drop a chip 10 times on a concrete floor from a height of 1 meter.</p>	<p>无外观损伤。 No visible damage.</p>															
<p>可焊性 Solderability</p>	<p>IEC 60068-2-58</p>	<p>① 焊接温度 Solder temperature: 245±5℃. ② 浸渍时间 Duration: 3±0.3s. ③ 焊锡成分 Solder: 96.5Sn/3.0Ag/0.5Cu. ④ 助焊剂 Flux: （重量比）25%松香和 75%酒精 25% Resin and 75% ethanol in weight.</p>	<p>① 无外观损伤； No visible damage. ② 元件端电极的焊锡覆盖率不小于 95%。 Wetting shall exceed 95% coverage.</p>															
<p>耐焊性 Resistance to Soldering Heat</p>	<p>IEC 60068-2-58</p>	<p>① 焊接温度 Solder temperature: 260±5℃. ② 浸渍时间 Duration: 10±1s. ③ 焊锡成分 Solder: 96.5Sn/3.0Ag/0.5Cu. ④ 助焊剂 Flux: （重量比）25%松香和 75%酒精 25% Resin and 75% ethanol in weight. ⑤ 试验后标准条件下放置 1~2 小时后测量。 The chip shall be stabilized at normal condition for 1~2 hours before measuring.</p>	<p>① 无外观损伤； No visible damage. ② $\Delta R_{25}/R_{25} \leq 2\%$ ③ $\Delta B/B \leq 1\%$</p>															
<p>温度周期 Temperature cycling</p>	<p>IEC 60068-2-14</p>	<p>① 无负载于下表所示的环境条件下重复 5 次。 5 cycles of following sequence without loading.</p> <table border="1" data-bbox="491 1509 1040 1704"> <thead> <tr> <th>步骤 Step</th> <th>温度 Temperature</th> <th>时间 Time</th> </tr> </thead> <tbody> <tr> <td>1</td> <td>-40±5℃</td> <td>30±3min</td> </tr> <tr> <td>2</td> <td>25±2℃</td> <td>5±3min</td> </tr> <tr> <td>3</td> <td>125±2℃</td> <td>30±3min</td> </tr> <tr> <td>4</td> <td>25±2℃</td> <td>5±3min</td> </tr> </tbody> </table> <p>② 试验后标准条件下放置 1~2 小时后测量。 The chip shall be stabilized at normal condition for 1~2 hours before measuring.</p>	步骤 Step	温度 Temperature	时间 Time	1	-40±5℃	30±3min	2	25±2℃	5±3min	3	125±2℃	30±3min	4	25±2℃	5±3min	<p>① 无外观损伤； No visible damage. ② $\Delta R_{25}/R_{25} \leq 2\%$ ③ $\Delta B/B \leq 1\%$</p>
步骤 Step	温度 Temperature	时间 Time																
1	-40±5℃	30±3min																
2	25±2℃	5±3min																
3	125±2℃	30±3min																
4	25±2℃	5±3min																
<p>高温存放 Resistance to dry heat</p>	<p>IEC 60068-2-2</p>	<p>① 在 125±5℃ 空气中，无负载放置 1000±24 小时。 125±5℃ in air, for 1000±24 hours without loading. ② 试验后标准条件下放置 1~2 小时后测量。 The chip shall be stabilized at normal condition for 1~2 hours before measuring.</p>	<p>① 无外观损伤； No visible damage. ② $\Delta R_{25}/R_{25} \leq 2\%$ ③ $\Delta B/B \leq 1\%$</p>															

片式 NTC 热敏电阻规格书 Specifications for Chip NTC thermistor

低温存放 Resistance to cold	IEC 60068-2-1	① 在-40±3℃空气中, 无负载放置 1000±24 小时。 -40±3℃ in air, for 1000±24 hours without loading. ② 试验后标准条件下放置 1~2 小时后测量。 The chip shall be stabilized at normal condition for 1~2 hours before measuring.	① 无外观损伤; No visible damage. ② $ \Delta R25/R25 \leq 2\%$ ③ $ \Delta B/B \leq 1\%$
湿热存放 Resistance to damp heat	IEC 60068-2-78	① 在 40±2℃, 相对湿度 90~95%空气中, 无负载放置 1000±24 小时。 40±2℃, 90~95%RH in air, for 1000±24 hours without loading. ② 试验后标准条件下放置 1~2 小时后测量。 The chip shall be stabilized at normal condition for 1~2 hours before measuring.	① 无外观损伤; No visible damage. ② $ \Delta R25/R25 \leq 2\%$ ③ $ \Delta B/B \leq 1\%$
高温负荷 Resistance to high temperature load	IEC 60539-1 5.25.4	① 在 85±2℃空气中, 施加允许工作电流 1000±48 小时。 85±2℃ in air with permissive operating current for 1000±48 hours ② 试验后标准条件下放置 1~2 小时后测量。 The chip shall be stabilized at normal condition for 1~2 hours before measuring.	① 无外观损伤; No visible damage. ② $ \Delta R25/R25 \leq 2\%$ ③ $ \Delta B/B \leq 1\%$

7 编带 Taping

类型 Type	0201
编带厚度 Tape thickness(mm)	0.5±0.15
编带材质 Tape material	纸带 Paper Tape
每盘数量 Quantity per Reel	15K

(1) 编带图 Taping Drawings

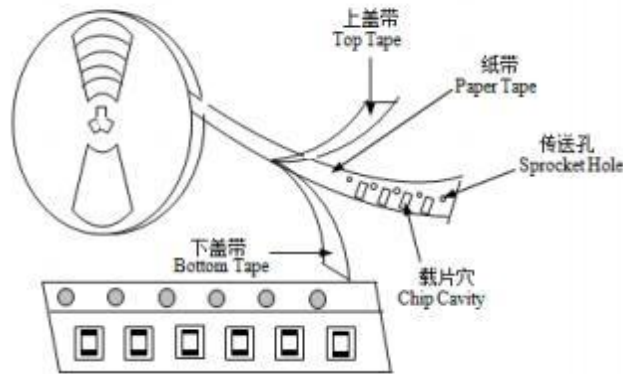

(2) 纸带尺寸 Paper Tape Dimensions (单位 Unit: mm)

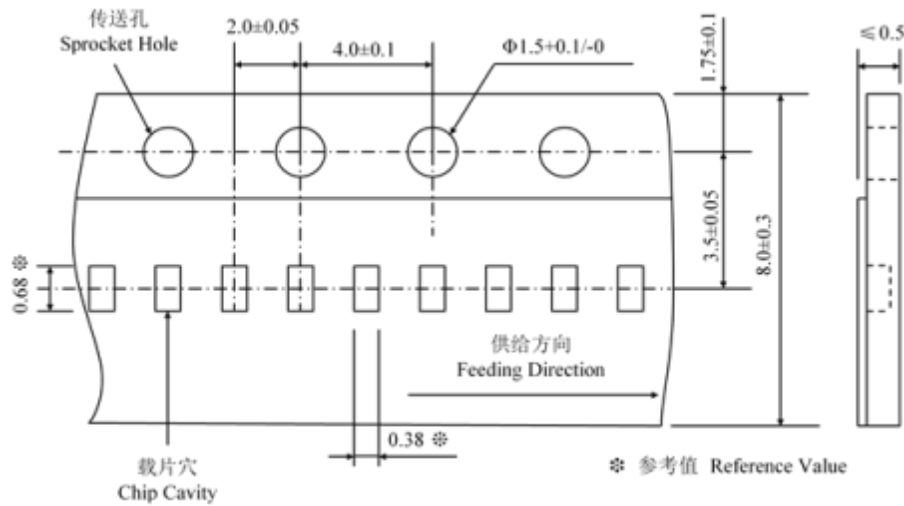

(3) 卷盘尺寸 Reel Dimensions (单位 Unit: mm)

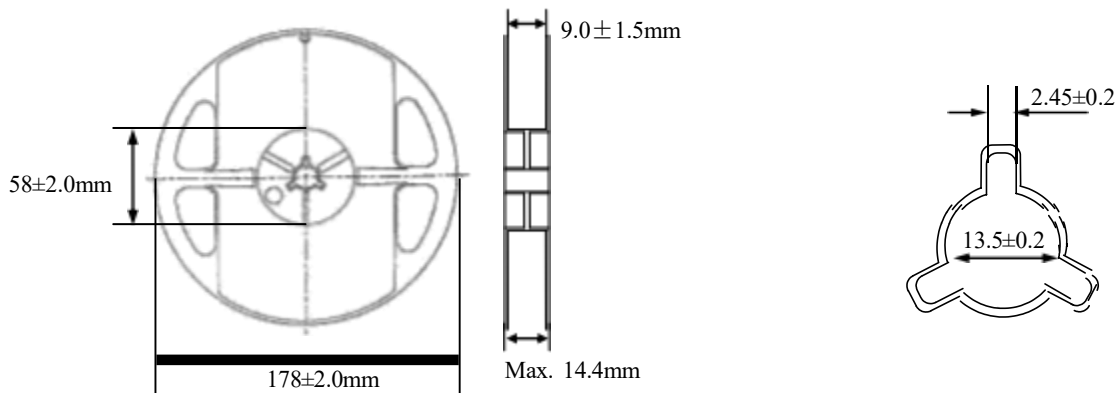

8 储存

· 储存条件

- 储存温度: -10℃~40℃
- 相对湿度: ≤75%RH
- 避免接触粉尘、腐蚀性气氛和阳光

· 储存期限: 6个月

8 Storage

· Storage Conditions

- Storage Temperature: -10℃~40℃
- Relative Humidity: ≤75%RH
- Keep away from corrosive atmosphere and sunlight.

· Period of Storage: 6 Months

9 注意事项

- NTC 系列热敏电阻不可在以下条件下工作或储存：
 - (1) 腐蚀性气体或还原性气体
(氯气、硫化氢气体、氨气、硫酸气体、一氧化氮等)。
 - (2) 挥发性或易燃性气体
 - (3) 多尘条件
 - (4) 高压或低压条件
 - (5) 潮湿场所
 - (6) 存在盐水、油、化学液体或有机溶剂的场所
 - (7) 强烈振动
 - (8) 存在类似有害条件的其他场所

- NTC 系列热敏电阻的陶瓷属于易碎材料，使用时不可施加过大压力或冲击。

- NTC 系列热敏电阻不可在超过目录规定的温度范围情况下工作。

10 建议焊接条件

- **回流焊**
 - 温升 1~2°C/sec.
 - 预热： 150~170°C/90±30 sec.
 - 大于 240°C 时间： 20~40sec
 - 峰值温度：最高 260°C/10 sec.
 - 焊锡： 96.5Sn/3.0Ag/0.5Cu
 - 回流焊： 最多 2 次

9 Notes & Warnings

- The NTC series thermistors shall not be operated and stored under the following environmental condition:
 - (1) Corrosive or deoxidized atmospheres
(such as chlorine, sulfurated hydrogen, ammonia, sulfuric acid, nitric oxide and so on)
 - (2) Volatile or inflammable atmospheres
 - (3) Dusty condition
 - (4) Excessively high or low pressure condition
 - (5) Humid site
 - (6) Places with brine, oil, chemical liquid or organic solvent
 - (7) Intense vibration
 - (8) Places with analogously deleterious conditions

- The ceramic body of the NTC series thermistors is fragile, no excessive pressure or impact shall be exerted on it.

- The NTC series thermistors shall not be operated beyond the specified "Operating Temperature Range" in the catalog.

10 Recommended Soldering Technologies

- **Re-flowing Profile**
 - 1~2°C/sec. Ramp
 - Pre-heating: 150~170°C/90±30 sec.
 - Time above 240°C: 20~40 sec.
 - Peak temperature: 260°C Max./10 sec.
 - Solder paste: 96.5Sn/3.0Ag/0.5Cu
 - Max.2 times for re-flowing

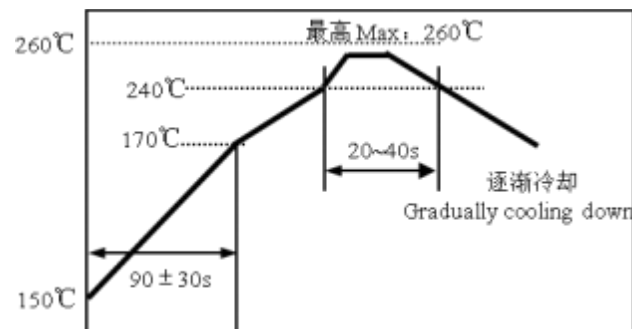

手工焊

- . 烙铁功率：最大 20W
- . 预热： 150°C/60sec.
- . 烙铁头温度：最高 280°C
- . 焊接时间：最多 3sec.
- . 焊锡： 96.5Sn/3.0Ag/0.5Cu
- . 手工焊： 最多 1 次

[注： 不要使烙铁头接触到端头]

Iron Soldering Profile

- . Iron soldering power: Max.20W
- . Pre-heating: 150°C/60sec.
- . Soldering Tip temperature: 280°C Max.
- . Soldering time: 3 sec Max.
- . Solder paste: 96.5Sn/3.0Ag/0.5Cu
- . Max.1 times for iron soldering

[Note: Take care not to apply the tip of the soldering iron to the terminal electrodes.]

